

1. Stöwer Kfz.4 AA

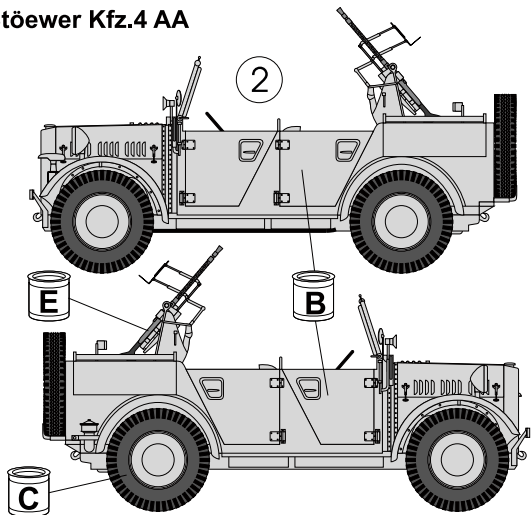

2. Stöwer Kfz.4 AA

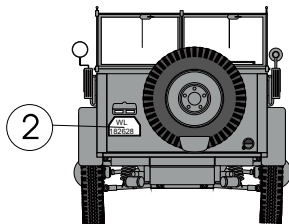
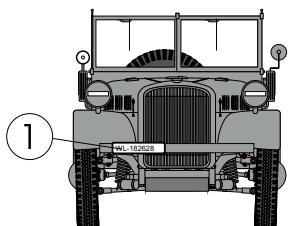
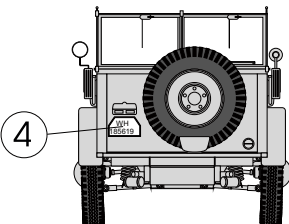
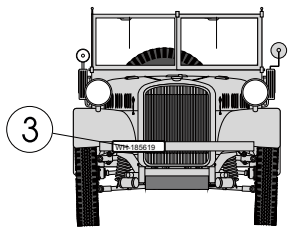
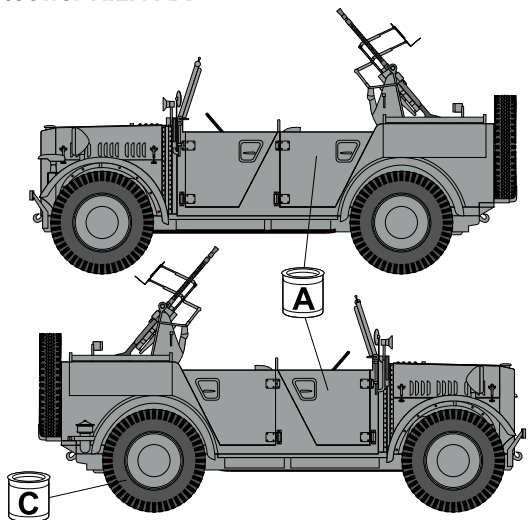

Při stavbě postupujte podle instruktážního obrázku

Follow the instruction drawing the assembly.

Upozornění: Během opracování může vznikat prach, který může dráždit dýchací cesty. Použijte ochranu očí při odšťihování kovových dílů.

Notice: Machining can produce dust which can be irritating to the respiratory tract. Metal parts should be cut off using protection eyesight.

Kupujte přímo na
www.plusmodel.cz

Plus Model s.r.o.
Jižní 56, 370 10 České Budějovice
Czech Republic
http://www.plusmodel.cz
e-mail: plusmodel@plusmodel.cz

Buy direct from
www.plusmodel.cz

www.plusmodel.cz

280

plus model

Scale
1/35

STÖEWER Kfz.4AA vehicle

Historie

Univerzální lehký terénní automobil, vyráběný firmou Stoewer v letech 1936 - 1943. Na výrobě se v letech 1937 - 1940 podílely také firmy BMW a Hanomag. Všechny vozy se v drobnostech lišily (firma BMW například používala šestiválcový motor).

Kromě starších Stoewer R180 Special a typu 40 z let 1940-43 měla všechna vozidla na prání řízení všech čtyř kol. Typy karoserie zahrnovaly Kfz.1 (čtyřmístná), Kfz.2 (spojovací), Kfz.2/40 (údržba a opravy) a Kfz.3 (lehké průzkumné vozidlo). Všechny typy byly používány na všech frontách II. světové války.

Technická data:

Motor - čtyřválcový kapalinou chlazený Stöwer AW2 OHV objem - 1997 cm³

Výkon - 37 kW (50k)

Spojka - suchá kotoučová

Převodovka - 5 stupňů vpřed, 1 vzad, přídavná jednostupňová

převodovka s mezinápravovým diferenciálem

Brzdy - mechanické

Rozvor - 2400 mm

Délka - 3900 mm

Šířka - 1690 mm

Výška - 1900 mm

Hmotnost - 1780 kg

History

Light Universal Off-road car was built by Stoewer company in 1933 - 1943 y. There was produced also by BMW a Hanomag companies. There were some differences between cars (e.g. cars from BMW company had six cylinder engine).

Except Stoewer R180 Special and type 40, all vehicles had all wheels controllable. There were used four variants of vehicle body: Kfz.1 (four man), Kfz.2 (liaison), Kfz.2/40 (repair) and Kfz.3 (light scout car).

All variants were used in all theatres of WW II. There were built about 13 000 vehicles, few of them survived.

Technical specifications:

Engine - Four cylinder Stöwer AW2 OHV, 1997 cm³, 37 kW (50 HP)

Gear box - Five forward, one reverse plus one auxiliary box

Clutch - Disc, dry

Brakes - Mechanical

Fuel capacity - 60 L gasoline

Wheel base - 2400 mm

Length - 3900 mm

Width - 1690 mm

Height - 1900 mm

Weight - 1780 kg

Kusovník a značení dílů - Numbering of parts
Resinové díly-Resin parts

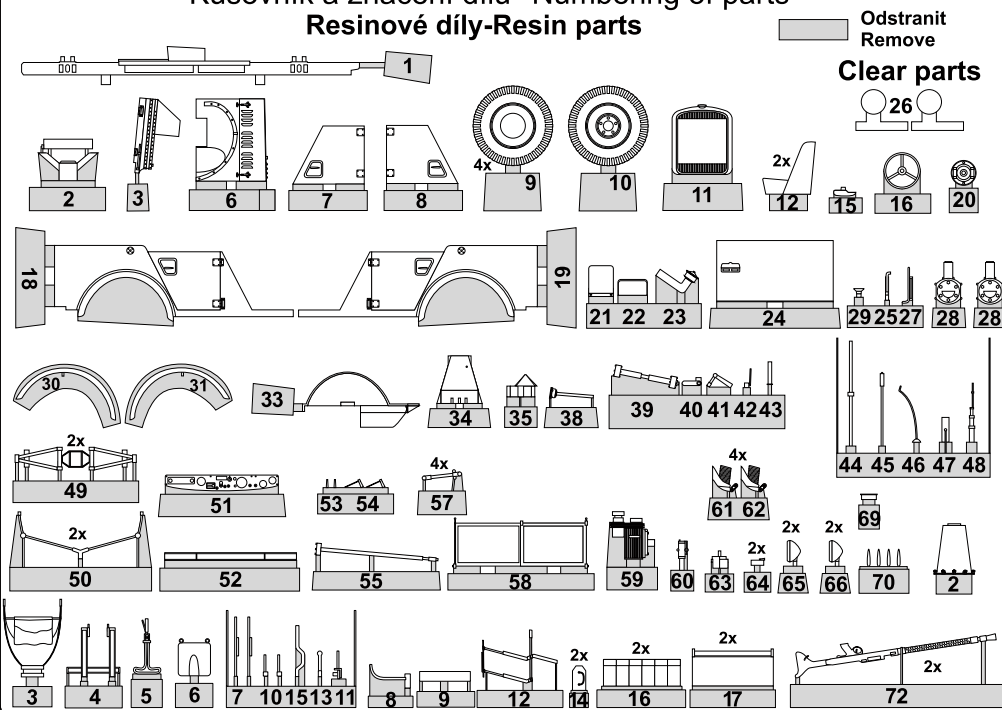

Kovové díly-Metal parts

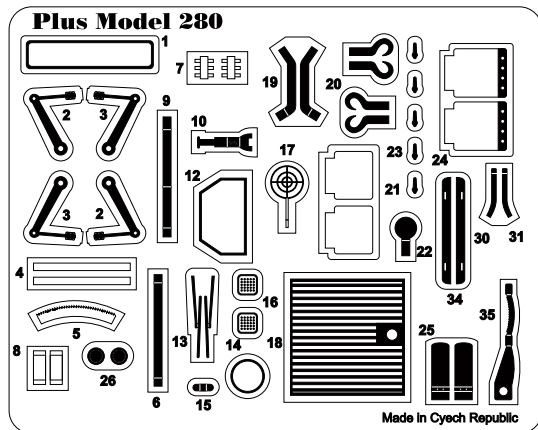

Obtisky-Decals

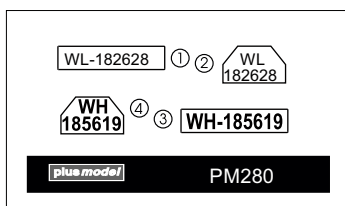

Fólie-Plastic film



Barvy - Colours

A Tanková šedá
Panzer Grey

B Pouštní žlutá
Desert Yellow

C Barva pneumatik
Tyre

D Středně šedá
Medium Grey

E Barva hlavní
Gunmetal

F Černá matná
Black Matt

G Hliníkový nátěr
Aluminium

H Stříbrná
Silver

I Bílá
White

Symboly - Symbols

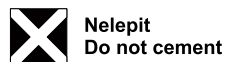
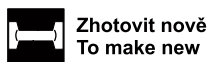

Stavební postup - Assembly instructions

22

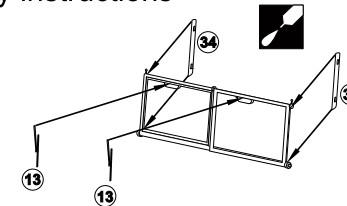
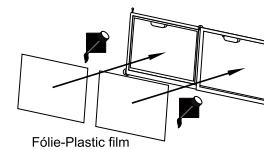
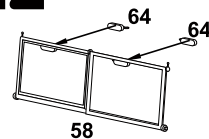

23

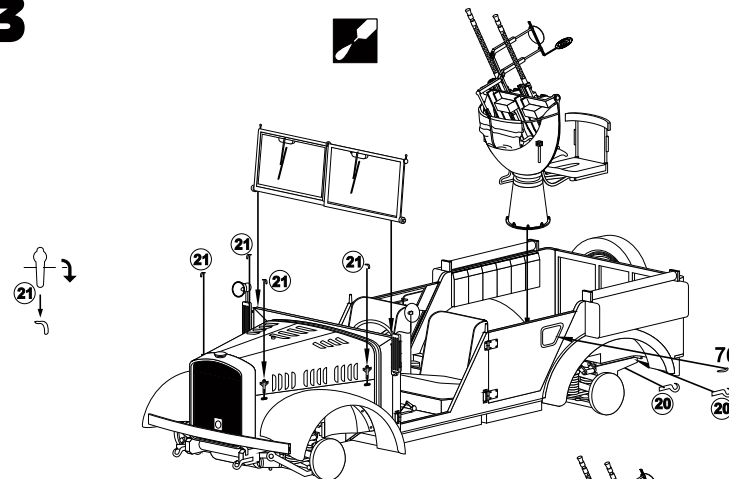

24

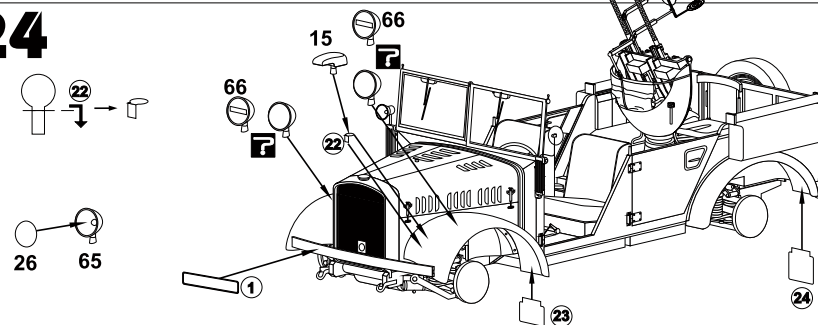

25

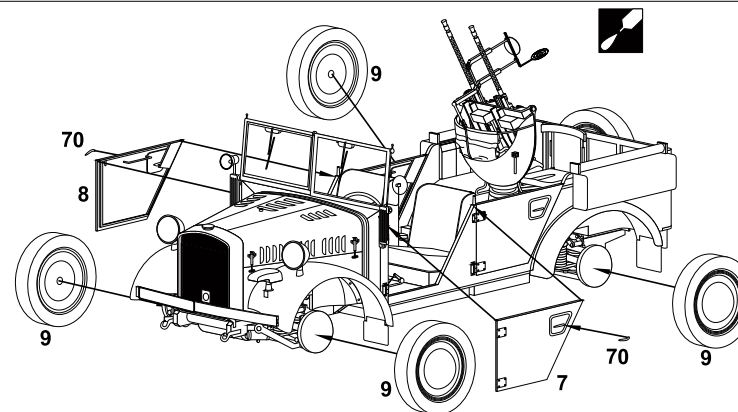

Stavební postup - Assembly instructions

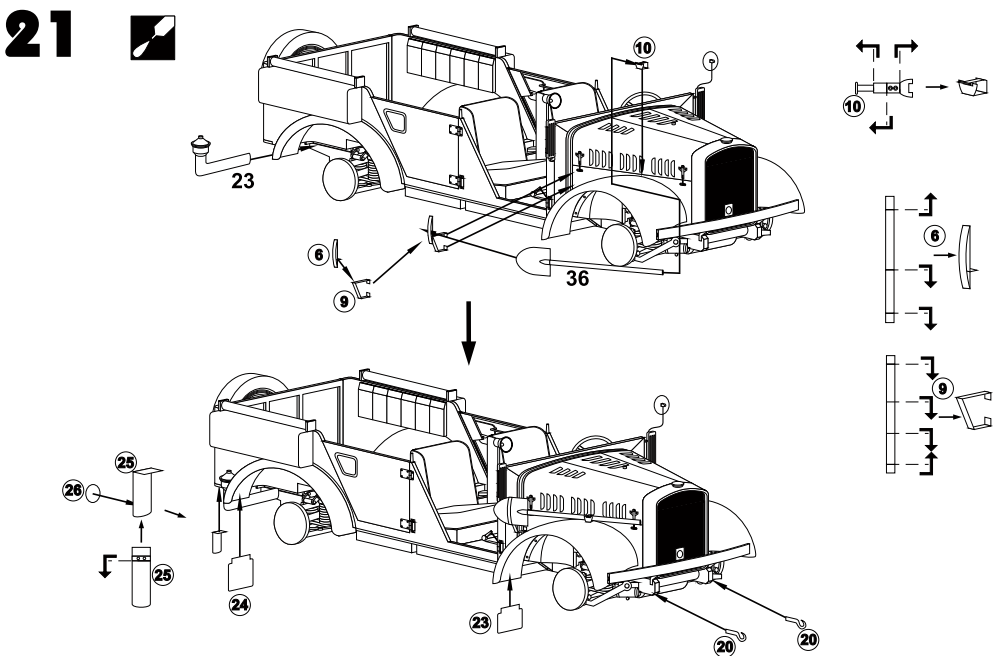
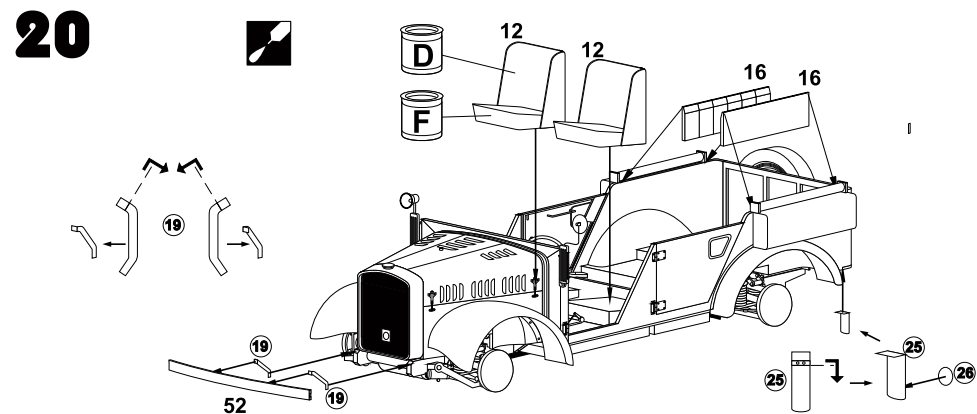
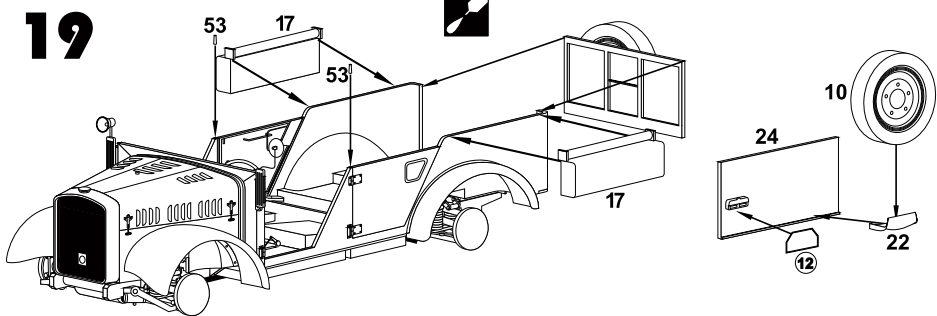

Stavební postup - Assembly instructions

